

ELDAN Rasps 807/1207



ELDAN Rasps 807/1207



Sophisticated manufacturing solutions will facilitate easy maintenance and reduce downtime.....

Standard rotor is made from wear-resistant, steel

The main rotor housing is equipped with replaceable wear plates to increase the durability of the machine.

Special tool-steel knives can be reground multiple times on a »flat-bed« grinder to ensure long life and low operating costs.

Adjustable knife clearance.

Serrated knife design available in different steel qualities.

Wedge mounted flying knives.
Screens available with different hole sizes.

Hydraulic opening of rotor housing for easy access to rotor and knives.

Friction clutches protects the drive system from momentary overload.

Reliable After-Sales-Service.

Ideal solution for preparing for instance cables for granulation

ELDAN RECYCLING A/S - Your logical choice of Partner

ELDAN RECYCLING A/S

Phone: +45 6361 2545, Fax: +45 6361 2540

Website: www.eldan-recycling.com

Technical Specifications

Specifications	Model 1207	Model 807
Rotor length mm	1200	800
Rotor diameter mm	332	332
Rotor speed rpm	120	120
Knives	12 flying/3 static	8 flying/2 static
Motor power	90 kW, 1400 rpm 3 ph, 400 V, 50 Hz*	75 kW, 1400 rpm 3 ph, 400 V, 50 Hz*
Length mm	1750	1750
Width mm	3250	2850
Height mm	3200	2700

* Standard voltage (by other voltages, please contact our Sales Department)

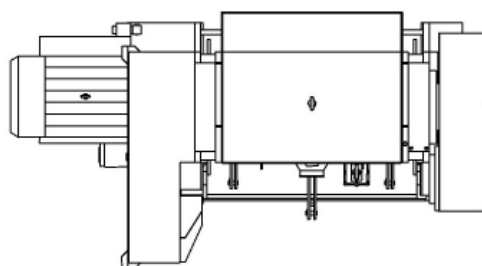
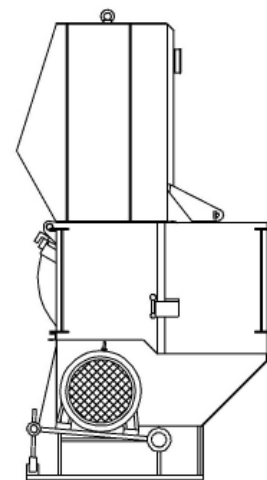
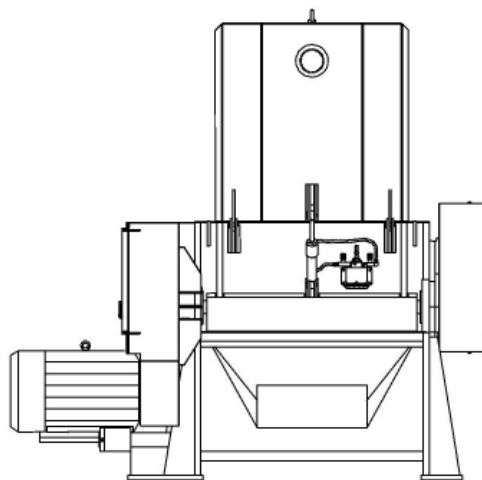

We reserve the right to alter and modify technical specifications and design without further notice